

Basic Principles of Electricity

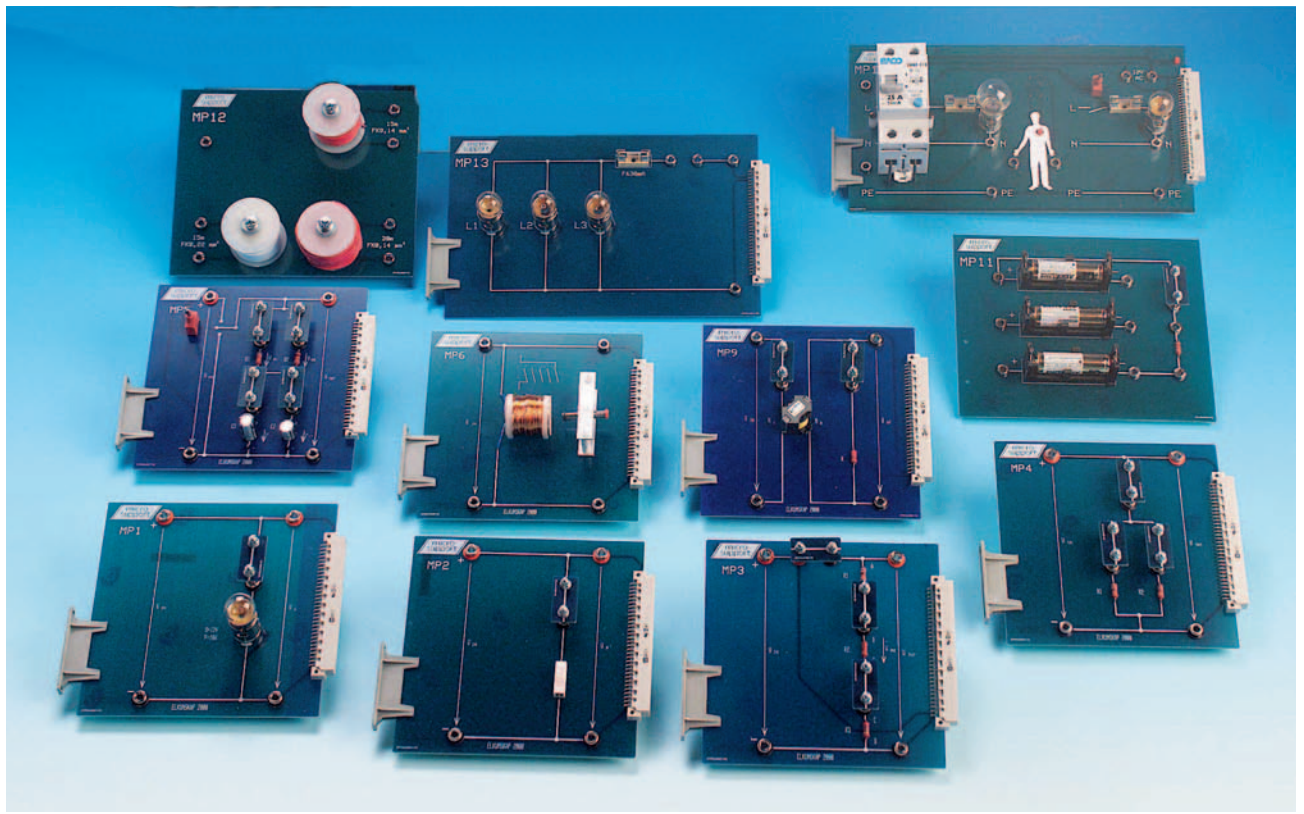
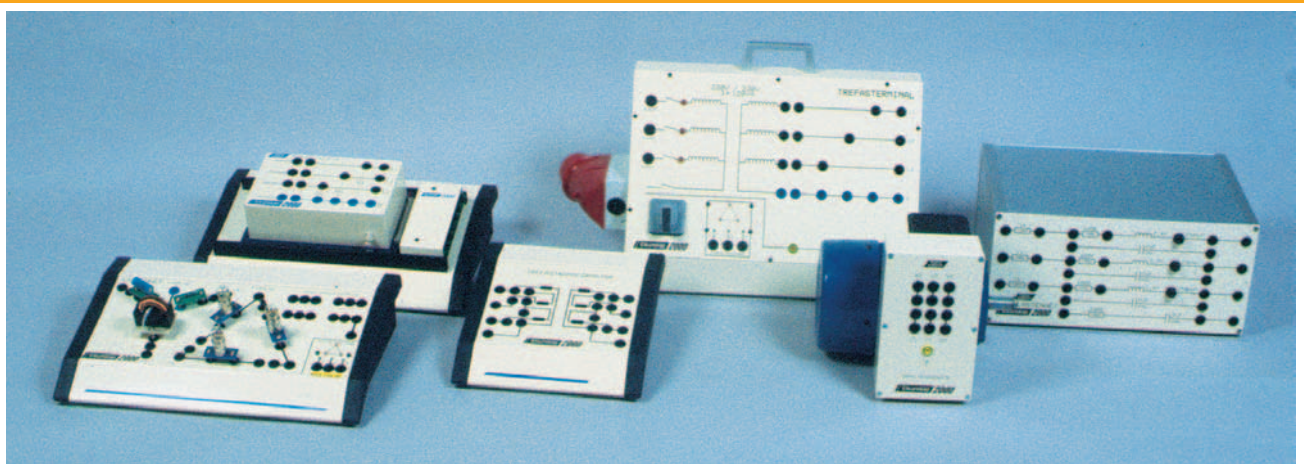

Contents

BASIC PRINCIPLES OF ELECTRICITY

DC AND SINGLE PHASE AC.....	2
ELE 102201 MP1 Power Measurement	4
ELE 102202 MP2 Verifying Ohm's Law	4
ELE 102203 MP3 Resistors in Series	4
ELE 102204 MP4 Resistors in Parallel	4
ELE 102205 MP5 The Capacitor.....	5
ELE 102206 MP6 Magnetism and Induction	5
ELE 102207 MP7 Loads R, L and C	5
ELE 102208 MP8 Phase Compensation.....	5
ELE 102209 MP9 The Transformer.....	6
ELE 102210 MP10 Measurement Techniques	6
ELE 102000 Base Unit.....	7
ELE 102001 HK1 Help Function Card.....	7
ELE 102002 HK2 Help Function Card.....	7
ELE 102004 IK Storage Rack	7
3-PHASE AC	8
ELE 102230 3 Phase Simulator	10
ELE 102234 3 Phase Transformer	10
ELE 102231 3 Phase Load Unit Low Voltage	10
ELE 102232 3 Phase Terminal.....	10
ELE 102233 3 Power Load Unit.....	11
ELK 102240 3 Phase Asynchronous Motor with Baseplate	11
ELE 102236 Motor/ Generator Model	11
ELE 102237 Capacitor Box	11
ELE 102238 Current Transformer/ Earth Leakage Breaker	12
ELE 102239 Heating Centre	12
LEY 500590 Safety Jumpers black	12
MV 1830-HF Laboratory Flex Set, Safety Plugs	12

Terco reserves the right to make changes in the design and modifications or improvements of the products at any time without incurring any obligations.

BASIC PRINCIPLES OF ELECTRICITY

DC and Single Phase AC

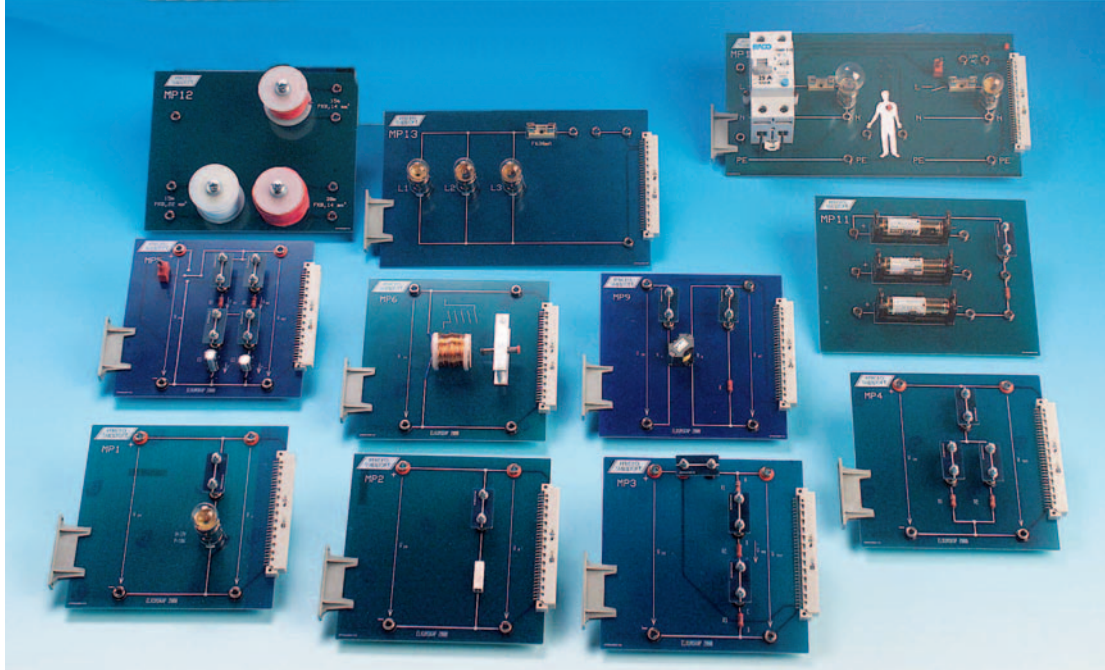

This modern laboratory equipment for DC and Single Phase AC consists of 10 laboratory cards which slot into the Base Unit 2000.

The laboratory package is designed to give basic knowledge of electricity when using DC and Single Phase AC.

It enables the student to be familiar with the oscilloscope, analogue and digital multimeters. How to connect, set and use and to be able to select the correct meter for each situation. The course teaches how to analyse measurements and use these measurements when fault finding in basic electrical circuits.

Topics Covered

- Measuring analogue and digital DC voltage
- Measuring DC current (MP1)
- Measuring resistance (MP1)
- Measuring power (MP1)
- Measuring resistors Ohms Law (MP2) Serial connection (MP3)
- Potential and potential difference (MP3)
- Parallel connection (MP4)
- Temperature dependence (MP1)
- The capacitor (MP5)
- Magnetism (MP6)
- Induction (MP7)
- The electric motor (MP6)
- The generator (MP6)
- Resistive loads (MP7)
- Coil and resistor (MP7)
- Capacitor and resistor (MP7)
- Phase compensation (MP8)
- Electrical machines (MP9)
- Circuits with high resistance (MP10)

DC and Single Phase AC

In this basic course the most common components used in electrical and electronic equipment are studied. e.g. resistors,isolators,batteries,capacitors and conductors. Theoretical studies include DC and AC current, electrical potential, static electricity,magnetism, induction, loads,electrical machines and measuring techniques.

Order Details:

Equipment

ELE 102000	Base Unit 2000
ELE 102001	HK1 Help Function Card
ELE 102201	MP1 Power Measuring
ELE 102202	MP2 Ohms Law
ELE 102203	MP3 Series connected Resistors
ELE 102204	MP4 Parallell connected Resistors
ELE 102205	MP5 Capacitor
ELE 102206	MP6 Magnetism/induction
ELE 102207	MP7 R, L and C as Load
ELE 102208	MP8 Phase Compensating
ELE 102209	MP9 Transformer
ELE 102210	MP10 Measuring Techniques
ELE 102004	Storage Rack 2-Row

Technical Literature

BOK 102203 DC and AC Laboratory Exercises

Contents:

Equipment

Power measurement

Ohms Law

Resistors in series

Resistors in parallel

Capacitors

Magnetism/Inductance

R,L & C as load

Phase compensation

Transformers

Measurement techniques

Extract from DC and AC Laboratory Exercises

Magnetism

The measurement lab-card consists of a coil and a movable permanent magnet. By passing current through the coil the magnet is affected. Connect up and calculate, with the help of the right hand rule, if the end of the coil nearest to the magnet will be North or South pole.

Verify the result by connecting 5V to the coil. The end marked with red on the magnet is a North pole.

Vary the voltage between 0 and 10V and turn the magnet to feel the pull from the electro-magnetism. Does it increase with increase of voltage?

Change the polarity. i.e. change over the plus and minus leads from the DC voltage supply. Repeat as above.

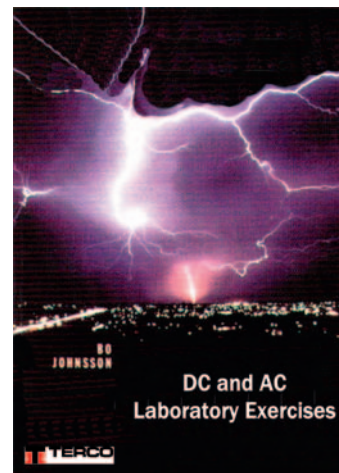

This book is well illustrated with diagrams and pictures

How is the magnetic field density measured?

Sketch the direction of the magnetic field.



Where is the North pole on the coil?

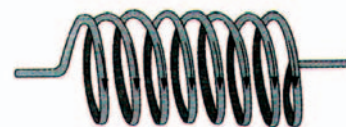

How can the magnetism be increased in the coil?

Which basic material can strengthen the magnetic field?

What is residual?

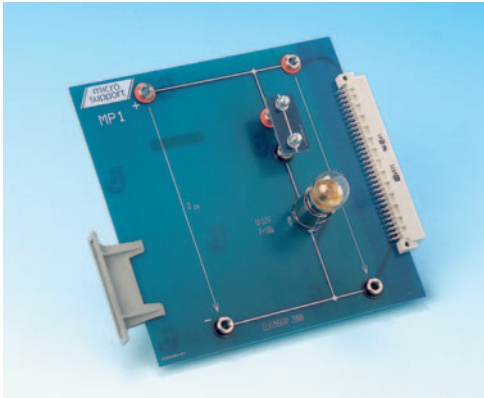

ELE 102201 MP1 Power Measurement

Measurement of DC current, resistance, power and effects of temperature.

General data:

Dimension: 160 x 140 x 40 mm

Weight: 0.2 kg

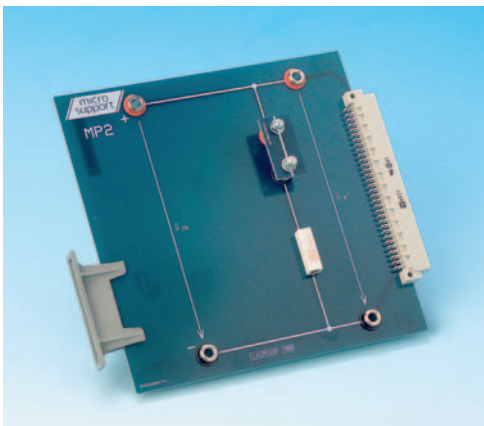

ELE 102202 MP2 Verification of Ohm's Law

Experiments to verify Ohm's Law. $V = I \times R$.

General data:

Dimension: 160 x 140 x 40 mm

Weight: 0.2 kg

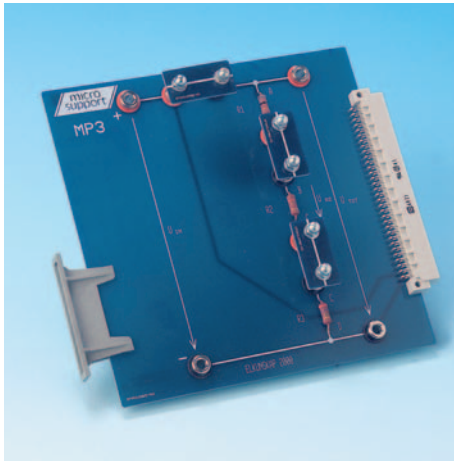

ELE 102203 MP3 Resistors in Series

Experiments with resistors connected in series.

General data:

Dimension: 160 x 140 x 40 mm

Weight: 0.2 kg

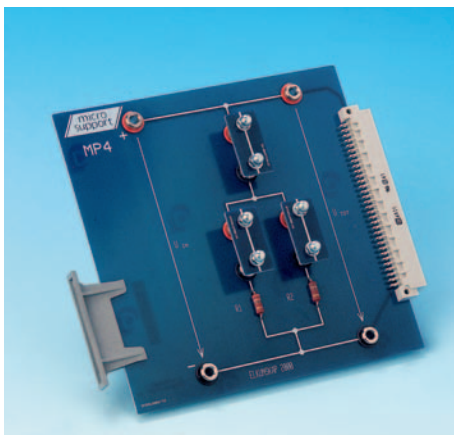

ELE 102204 MP4 Resistors in Parallel

Experiments with resistors connected in parallel.

General data:

Dimension: 160 x 140 x 40 mm

Weight: 0.2 kg

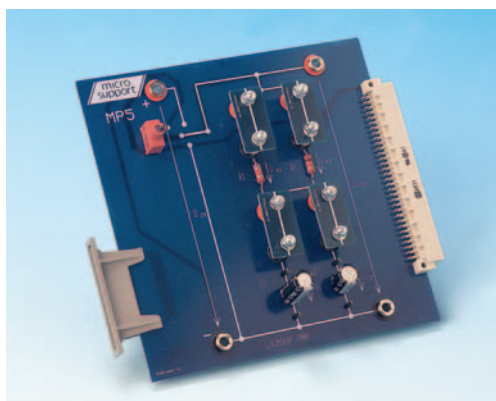

ELE 102205 MP5 The Capacitor

Experiments with capacitors connected in different circuits.

General data:

Dimension: 160 x 140 x 40 mm

Weight: 0.2 kg

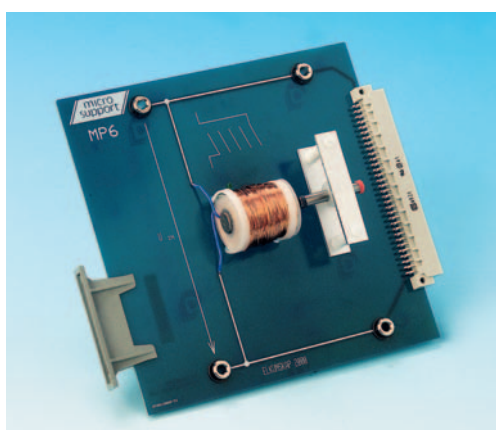

ELE 102206 MP6 Magnetism and Induction

Experiments with magnetism and induced emf.

General data:

Dimension: 160 x 140 x 40 mm

Weight: 0.2 kg

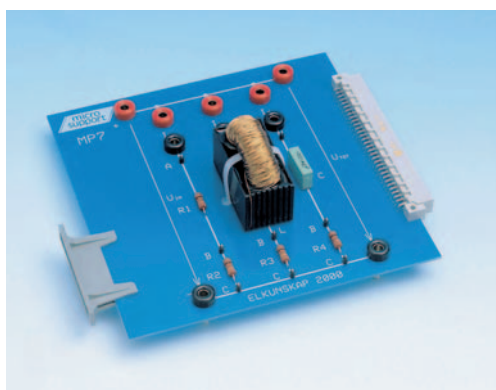

ELE 102207 MP7 R, L, and C Loads

Experiments with resistance, inductance and capacitance in AC circuits.

General data:

Dimension: 160 x 140 x 40 mm

Weight: 0.2 kg

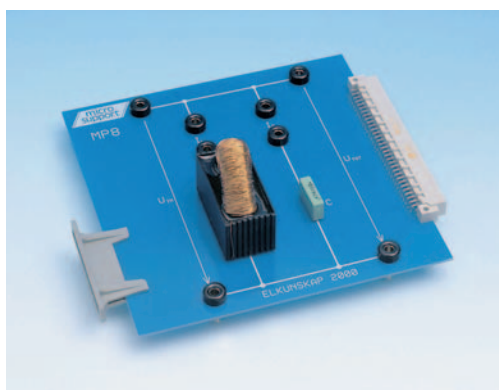

ELE 102208 MP8 Phase Compensation

Experiments with capacitors to compensate phase difference.

General data:

Dimension: 160 x 140 x 40 mm

Weight: 0.2 kg

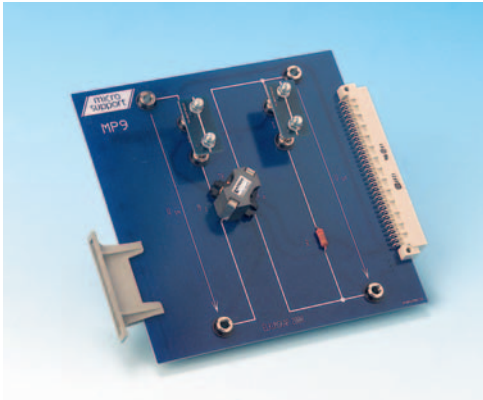

ELE 102209 MP9 The Transformer

Experiments with voltage transformation.

General data:

Dimension: 160 x 140 x 40 mm
Weight: 0.2 kg

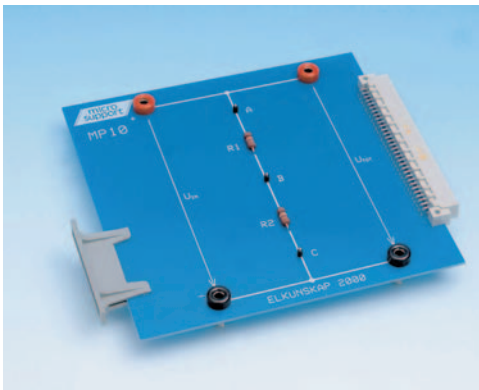

ELE 102210 MP10 Measurement Techniques

Measurement of high resistance circuits.

General data:

Dimension: 160 x 140 x 40 mm
Weight: 0.2 kg

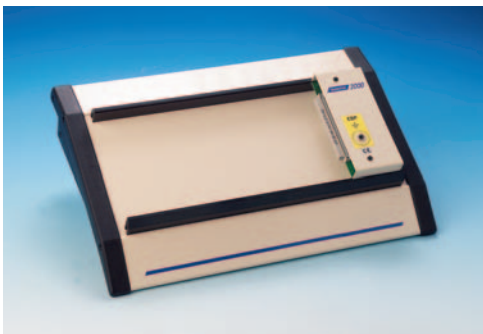

ELE 102000 Base Unit 2000

The starting point of this laboratory system is Base Unit 2000, a control box and PCB-holder.

The Base Unit can be loaded with laboratory cards which have been carefully designed to suit each particular area of study.

The Lab Cards are placed in slots and are automatically powered via a D-sub connector.

General Data:

Supply voltage: 220 - 240V 50-60Hz 1-phase.

The unit has 6 outputs with following data:

Output 1-3: DC 12V / 3A with LED indication and fuse.

Output 4-6: AC 24V / 3A with LED indication and fuse.

Dimension: 370 x 180 x 75 mm.

Weight: 4 kg

Other supply voltages available on request.

Terco reserves the right to make changes in the design and modifications or improvements of the products at any time without incurring any obligations.

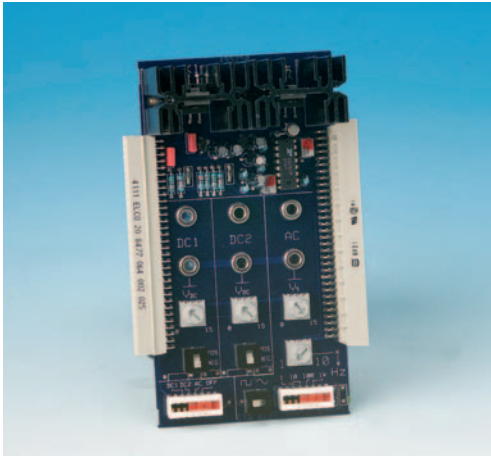

ELE 102001 HK1 Help Function Card

HK1 Help Function Card serves as an additional power supply and function generator. The HK1 slots into the Base Unit 2000, and Lab Cards 1 to 8 slot into HK1.

General data:

DC Output 1: 0 – +15V (5V/1.6A 10V/1.0A 15V/0.1A)
DC Output 2: 0 – - 15V (5V/1.6A 10V/1.0A 15V/0.1A)
Sinus wave 1Hz to 10kHz in 4 steps
Square wave 1Hz to 10kHz in 4 steps
Amplitude 0-15V/8W

Dimension: 140 x 75 x 52 mm

Weight: 0.2kg



ELE 102009 HK2 Help Function Card

HK2 Help Function Card serves as an additional power supply. The HK2 slots into the Base Unit 2000, and gives a variable voltage between 1.2 - 30V DC. It can be used wherever a variable voltage is required.

General data:

Variable DC output between 1.2 - 30V
Max Current 1A
Dimension: 140 x 75 x 52 mm
Weight: 0.2 kg

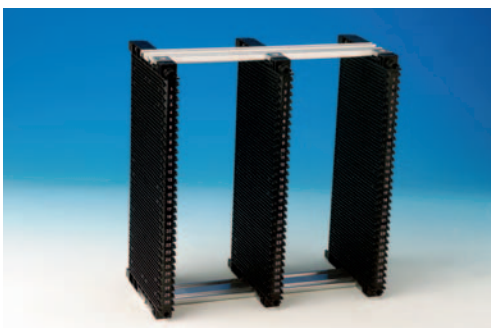

ELE 102004 Storage Rack

A system storage rack for safe storage of the lab cards. It is constructed of hard plastic and very durable.

General Data:

Dimension: 340 x 180 x 355 mm
Weight: 2 kg

3-PHASE AC

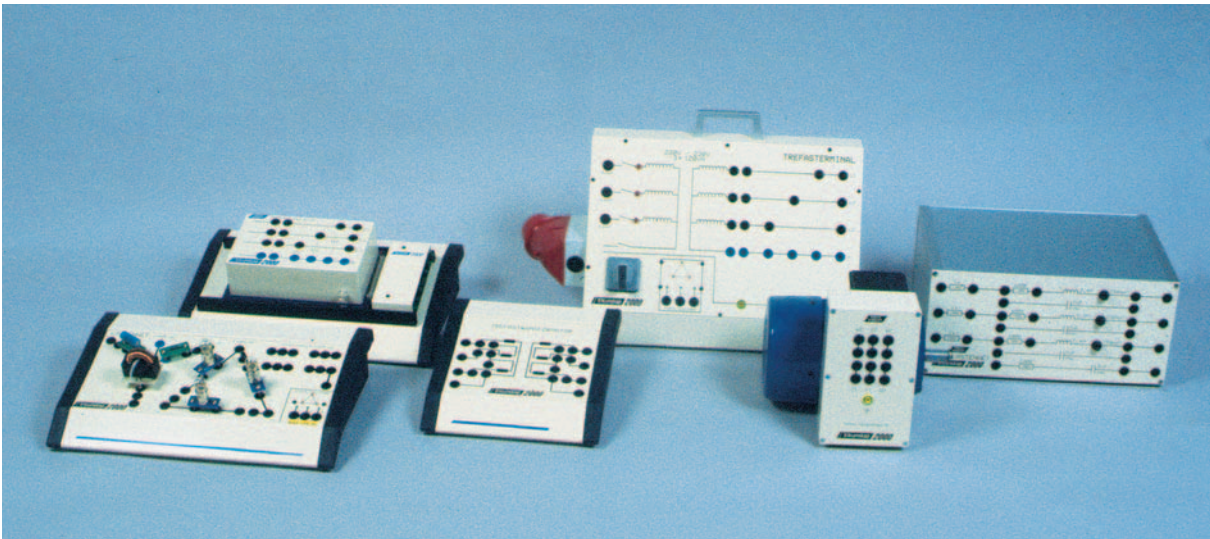

3-PHASE AC

In this section, basic knowledge of 3-phase systems is studied. These include single phase and three phase systems, phase difference, motors, three phase transformers and control of motors. The practical exercises are completed in two stages, first using extra low voltage (14V) and finally with supply voltage 380-415V, 3 phase, 50-60Hz.

This laboratory package for 3-phase consists of a 3-phase simulator board which produces a 3-phase sine wave voltage of 14V. There is also a measuring point, power output (touch protected) and 4 fault finding switches. The board is used together with the Base Unit 2000.

The 3-phase simulator board has a multiplexer function which enables the student to study three different waveforms on one channel on the oscilloscope.

To study the different types of load, a special load unit for the 3-phase simulator board is used. The student can connect in Y, D, series and parallel, with different loads. A phase sequence meter is also included.

Using the 3-phase terminal, 400V AC can be connected. Different loads can be applied from the load unit which has R, L and C loads.

7 multimeters are required, (preferably with both analogue and digital scales). 1 wattmeter and an oscilloscope with digital memory are also required in order to complete the course.

This course is a continuation from the course in DC and single phase AC circuits. It provides a sound base for the study of electrical engineering and basic knowledge of 3-phase AC. The ability to calculate and solve problems with different types of load with phase difference, is developed. The knowledge and skill required to complete fault finding and the ability to correct faults in equipment used in a 3-phase system can also be achieved.

Terco reserves the right to make changes in the design and modifications or improvements of the products at any time without incurring any obligations.

3-Phase AC

Order Details

Equipment

ELE 102000	Base Unit 2000
ELE 102230	3-Phase Simulator
ELE 102234	3-Phase Transformer
ELE 102232	3-Phase Terminal
ELE 102233	3-Phase Power Load Unit
ELK 102240	3-Phase Asynchronous Motor with Base Plate
LEY 500590	Security Jumper black
MV 1830-HF	Lab Flex Set Safety Plug

Extracts from the Laboratory Experiment Book

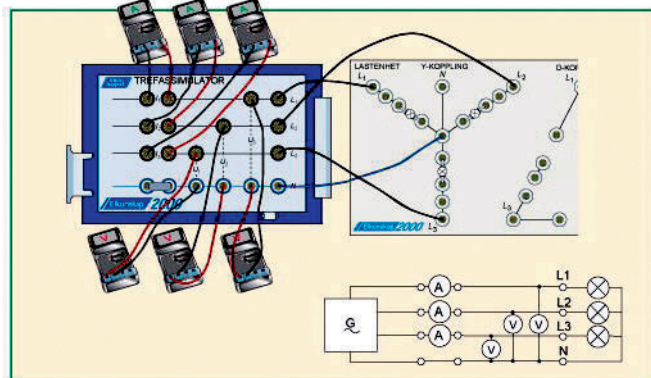

3.2 Measurement of a star (Y) connection.

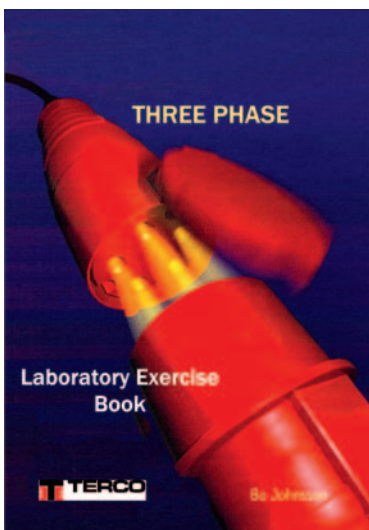

Delta Connection

Do **not** switch on the Base Unit.

Connect the measuring instruments and the 3 resistors (33ohms) in delta formation as shown in 3.4.

Fill in the measured values in the table.

Calculate the power in each resistor and enter the values in the table.

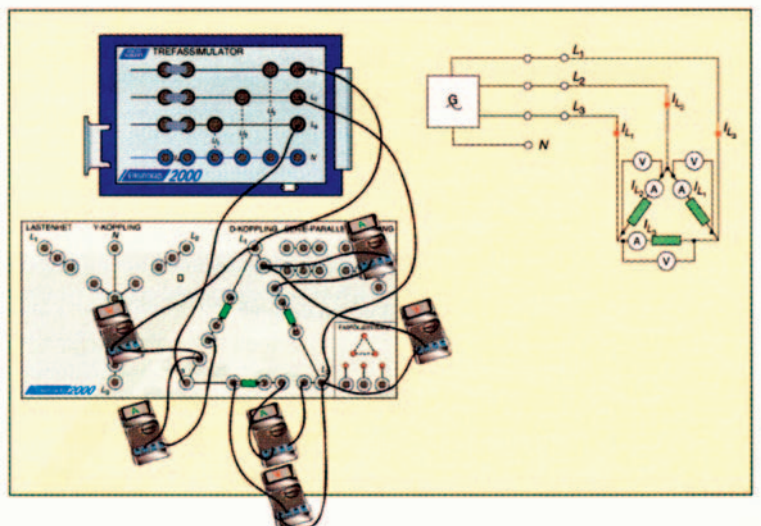

Calculate the total power.
Describe the relationship between the power developed in D resp.Y connections.

Technical Literature 3-phase

BOK 102212 Laboratory Exercise Book

Contents:

- Measuring instruments
- Supply voltage and 3 Phase
- Balanced loads
- Unbalanced loads
- Phase shift
- Power measurement
- Phase compensation
- The transformer
- Motors
- Fault finding



ELE 102230 3-Phase Simulator

The 3-phase simulator is used as a voltage source for most of the exercises using 3 phase.

General data:

Dimension: 100 x 140 x 40 mm

Weight: 1kg



ELE 102234 3-Phase Transformer

The 3-phase transformer is designed to connect to the 3 phase simulator. Setting 1:2. The unit can be connected in different combinations of star(Y) and delta (D).

General data:

Dimension: 260 x 220 x 90 mm

Weight: 2.2 kg



ELE 102231 3-Phase Load Unit Low Voltage

The 3-phase load unit is connected to the 3 phase simulator. From the load unit resistive, inductive and capacitive loads can be connected. These can be connected in star (Y) or delta (D). A phase rotation meter for voltages under 50V is built into the unit. The unit is delivered complete with the load components.

General data:

Dimension: 400 x 170 x 315 mm

Weight: 12 kg

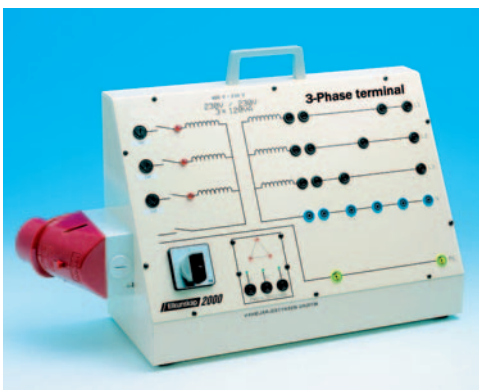

ELE 102232 3-Phase Terminal

The 3-phase terminal is used for experiments which require connection to a 3 phase supply. The terminal has a current switch, lamp indication, isolating transformer and a phase sequence meter. Connection is made via touch protected sockets.

General data:

Dimension: 390 x 260 x 90 mm

Weight: 2.5 kg



ELE 102233 3-Phase Power Load Unit

The 3 phase power load unit contains load components R, L, and C for use on supply voltage of 230/240 V. Connection is made via touch protected sockets.

General data:

Dimension: 350 x 250 x 180 mm
Weight: 8.5 kg



ELK 102240 3-Phase Asynchronous Motor with Baseplate

A 3ph asynchronous motor having a suitable baseplate for connection to the brake unit. It can also be used in the course for motor control.

General data:

Power: 250 VA
Voltage: 230/400 V

Dimension: 280 x 220 x 180 mm
Weight: 9 kg



ELE 102236 Motor/Generator Model

This model consists of 3 coils which can be connected in Y or D. The coils have iron cores which are easily removed. The unit is complete with two rotors, one magnetic and one of metal plate. The 3 phase simulator is used to supply this model.

General data:

Dimension: 290 x 265 x 60 mm
Weight: 2.5 kg



ELE 102237 Capacitor Box

Three motor capacitors are mounted on a podium box. Connection is via touch protected sockets. The capacitors can be connected in series or parallel.

General data:

Capacitance: 3 x 15 μ F
Voltage: 450 V

Dimension: 240 x 220 x 150 mm
Weight: 2 kg

Terco reserves the right to make changes in the design and modifications or improvements of the products at any time without incurring any obligations.

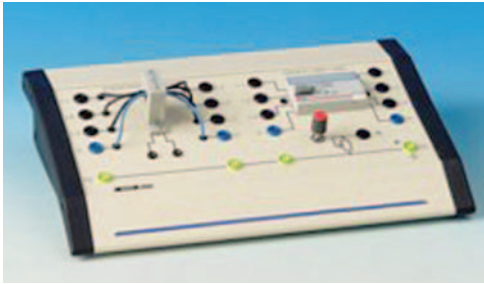

ELE 102238 Current Transformer/ Earth Leakage Circuit Breaker

This unit consists of a current transformer and an automatic circuit breaker mounted on a pulpit box. Connection is via touch protected sockets.

General data:

CT measuring range: 0.5 - 5A AC

Output Voltage: 0.1 - 4 V

ELCB 4 pole

Dimension: 390 x 260 x 140 mm

Weight: 3 kg



ELE 102239 Heating Centre

Two single phase outlets and a metal pipe are mounted on a pulpit box. The pipe is used to simulate a water pipe which can cause stray currents. Connection is via touch protected sockets.

General data:

Dimension: 260 x 220 x 90 mm

Weight: 1.5 kg



LEY 500590 Safety Jumpers

Short circuiting 4 mm black jumpers used for connecting motors etc

Dimension: 38 x 26 x 8 mm

Weight: 0.05 kg.



MV 1830-HF Lab Flex Set, Safety Plugs

A stiff protection socket covers the plug.

Set of 100 leads in 5 different colours, red, yellow, blue and yellow/green. 5 each of 4 different lengths, 25, 50, 100 and 200 cm.

Area: 1.5 mm²

Terco Headoffice



Terco headoffice and factory outside Stockholm, Sweden.

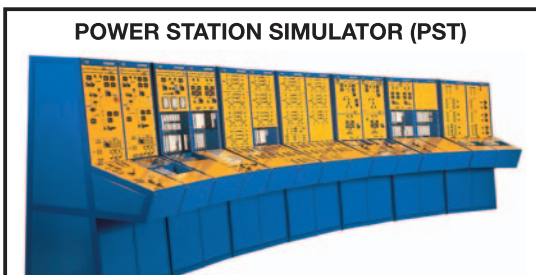

POWER STATION SIMULATOR (PST)



PROTECTION RELAYS

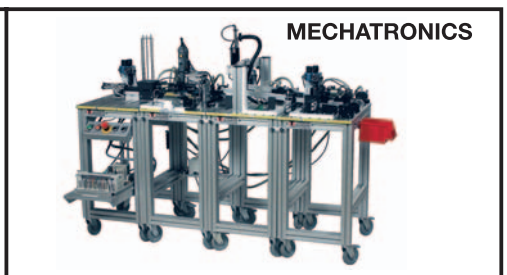

MECHATRONICS

TERCO AB • P.O. Box 5014 • SE-141 05 HUDDINGE – STOCKHOLM • SWEDEN
 Telephone: +46 8 506 855 00 • Telefax +46 8 506 855 01 • <http://www.terco.se> • e-mail export@terco.se